

MPET-SERIES MULTI-PHASE EXTRACTION REMEDIATION SYSTEMS

MPET-SERIES MULTI-PHASE EXTRACTION REMEDIATION SYSTEMS

Each MPET-Series system can be customized to meet your remediation needs. Some of these changes may include increased flow rates and/or equipment changes based on technology preference or site requirements. Additional or altered treatment modules include, but are not limited to:

- **Adjustments to System Air Flow**
Each system air flow shown in the system performance table can be adjusted if it does not meet or exceeds your remediation needs. This may affect the motor used to drive the multi-phase extraction blower, which, in turn, could alter the power draw (horsepower) required by the system blower.
- **Liquid-Phase Carbon Filtration Vessels**
Filtration media used to increase treatment efficiency by removing concentrations of VOCs that were not captured by the diffused-aeration stripper.
- **Organo Clay Filtration Vessels**
Filtration media designed to remove VOCs composed of large carbon chains that are difficult to strip and would consume large amounts of carbon.
- **Filtral Filtration Vessels**
Filtral filtration media designed to remove metals from groundwater including arsenic, lead, fluoride, chromium, zinc, iron and phosphates.
- **Bag Filtration Units**
Used as an economical solution for removing particulate before treating groundwater with various media vessels.
- **Multi-Phase Extraction Manifolds**
Custom-designed manifolds are available for each system to accommodate the flow rate and the number of wells being drawn from on site.
- **Off-Gas Treatment**
Vapor-phase carbon vessels, electric-catalytic oxidizers, thermal oxidizers or thermal-catalytic oxidizers can be supplied by MAE2 to meet specific off-gas requirements.
- **Water Storage Tank**
Plastic storage tank used to store discharge groundwater for future disposal, or provide retention time to eliminate emulsified product.
- **Mobile Enclosure**
Each modified shipping container system enclosure can be upgraded to an enclosed, mobile unit with similar standard features and characteristics.
- **Web-Based Telemetry**
Each control system can be upgraded to include wireless web-based telemetry to provide remote system access/startup, email or text message on system alarm, daily EMonitor system-status report and full data-logging capabilities.

(Please note that altering the MPET-Series systems may affect the enclosure size)

Mid-Atlantic Environmental Equipment, Inc.

Is a proud distributor of environmental remediation systems manufactured by:

MLE Equipment, Inc.

Mid-Atlantic Environmental Equipment (MAE2) is proud to introduce our new line of multi-phase extraction packaged systems: the MPET-Series. Each system within the series uses either rotary-claw or liquid-ring pump technology to retrieve contaminated vapors and groundwater under a high vacuum, while providing treatment for a wide range of both air and water-flow rates. Each system is third-party certified (MET certification), self-contained in an enclosure, and engineered with easy equipment access for operation and maintenance.

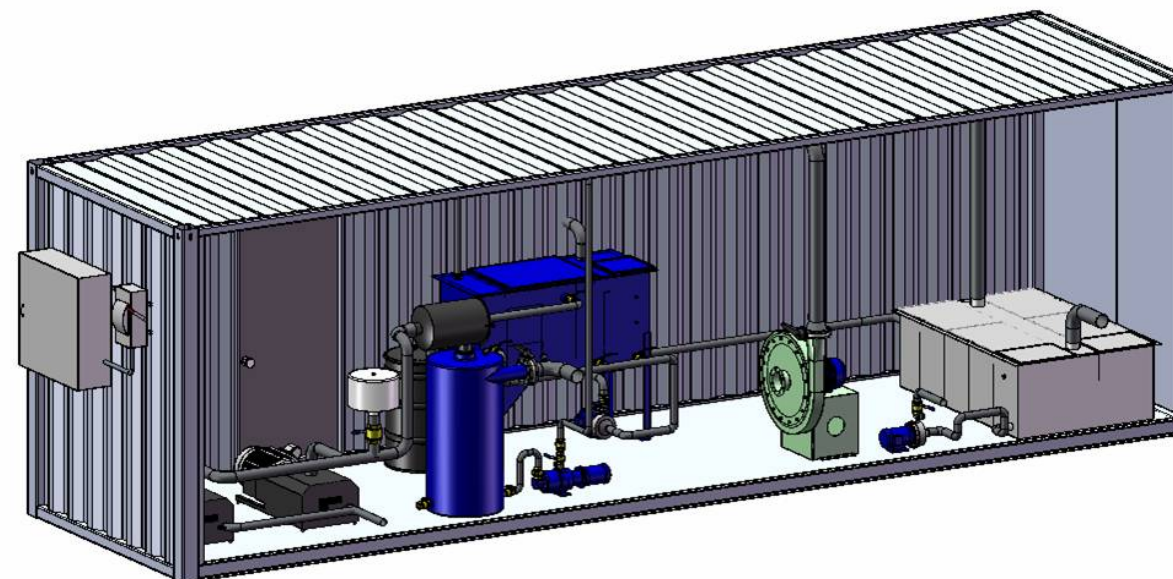

TOP VIEW

END VIEW

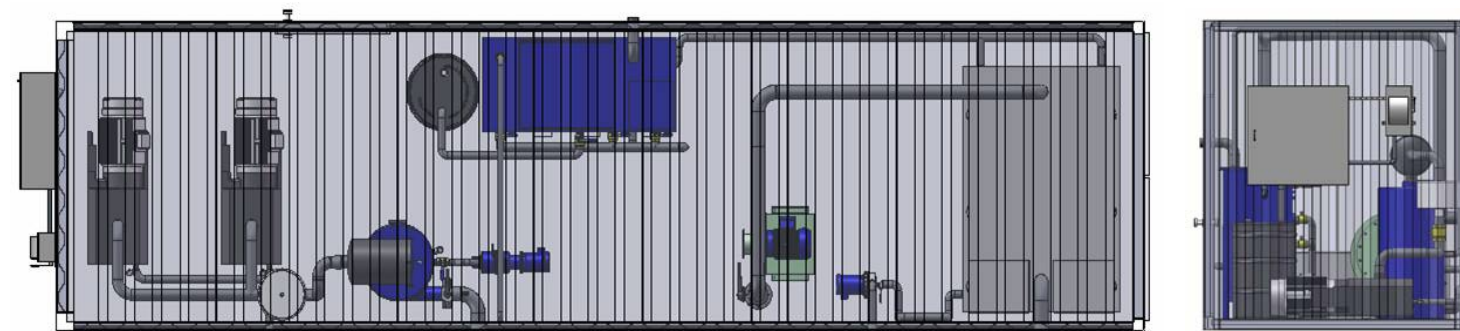



MPET-SERIES MULTI-PHASE EXTRACTION REMEDIATION SYSTEMS

MPET-SERIES MULTI-PHASE EXTRACTION REMEDIATION SYSTEMS

The MPET-Series offers a flexible, cost-effective solution for multi-phase extraction and water-treatment applications. The specifications of each system are outlined in the table below, followed by detailed descriptions of the standard system components. Each model number ending in the letter "C" indicates the use of rotary-claw blower technology, while each model number ending in the letter "L" indicates the use of liquid-ring pump technology.

PRODUCT NUMBER	AIR FLOW (ACFM)	VACUUM RANGE ("Hg)	POWER DRAW (HP)	ANNUAL POWER SAVINGS VS. LRP	AIR INLET PIPING	AIR DISCHARGE PIPING	APPROX ENCLOSURE SIZE (L x W x H)
MPET-160C	160	5 - 23	7.5	\$1,250	3"	2"	8' x 20' x 8'10"
MPET-320C	320	5 - 23	15	\$2,500	4"	2"	8' x 25' x 8'10"
MPET-480C	480	5 - 23	21.5	\$6,000	4"	2"	8' x 30' x 8'10"
MPET-160L	160	15 - 28	10	N/A	3"	2"	8' x 25' x 8'10"
MPET-375L	375	15 - 28	25	N/A	4"	2"	8' x 25' x 8'10"
MPET-500L	500	15 - 28	40	N/A	4"	2"	8' x 30' x 8'10"
MPET-800L	800	15 - 28	60	N/A	6"	3"	8' x 35' x 8'10"

VAPOR/LIQUID SEPARATOR MODULE:



The purpose of this module is to separate the extracted materials into two phases: liquid and vapor. The liquid is separated from the vapor and pumped through the water-treatment process, while the vapor is discharged to the inlet of the extraction blower. The standard separator used is a carbon steel MAE2 VLW-90, which has a total volume of 90 G and a water storage volume of 56 G. The separator is capable of operating under vacuums to 29" Hg while providing 98% water-removal efficiency. Also, the VLW-90 can be modified to accommodate systems that require an air flow greater than 500 ACFM. Each MPET system uses a progressive-cavity transfer pump to pump the discharge water to be treated.

ROTARY CLAW MUTLI-PHASE EXTRACTION BLOWER MODULE:

As mentioned above, the mixture of vapor and liquid is extracted from the ground using rotary-claw technology. Rotary-claw blowers are ideal for high-vacuum extraction applications at a low to mid-range air-flow rate. They require less maintenance and have a lower power draw compared to liquid-ring pumps of a similar performance, and can be more cost effective depending on system requirements. For example, it is expected that the MPET-160, 320 and 480 will save approximately \$1,250, \$2,500 and \$6,000 respectively in yearly power supply costs compared to liquid-ring pumps of a similar performance. Each rotary-claw unit is self-contained in an enclosure with an integral discharge silencer, inlet filter and vacuum-relief valve. Each rotary-claw blower used in the MPET-Series systems is equipped with an auto-oiler that prevents the claws from seizing due to moisture.

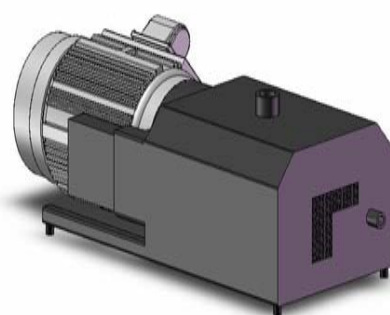

LIQUID-RING PUMP MUTLI-PHASE EXTRACTION BLOWER MODULE:

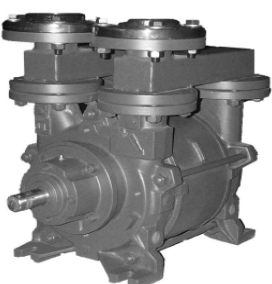

Liquid-ring pumps are another accepted blower technology used in multi-phase extraction applications. MAE2 specializes in manufacturing packaged water-seal and oil-seal modules, rather than purchasing fully assembled packages from an outside supplier for resale. The power draw of our liquid-ring pump packages is typically between 10 and 60 horsepower (up to approximately 800 ACFM). However, we also have experience integrating up to eight 100 horsepower pumps into a single multi-phase extraction system (in excess of 8000 ACFM). Liquid-ring pumps are ideal for long term multi-phase extraction applications where high air flow and vacuum are necessary.

OIL/WATER SEPARATOR MODULE:

An MAE2 OWS-Series oil/water separator is used in each MPET-Series system to remove free product from the extracted groundwater. Contaminated water is pumped from the vapor/liquid separator discharge into the inlet of the oil/water separator, where it passes through coalescing media. The media attracts droplets of free product to the surface where they are collected by a rotary skimmer and stored in a 55 G external product storage tank. Once the free product is removed, the remaining groundwater gravity drains into the Air Stripper Module. The oil/water separator used in each MPET-Series system is custom designed to accommodate the specific gravity and desired micron size removal of the contaminant found on site. These oil/water separators can be fabricated from sandblasted carbon steel with an epoxy coating, stainless steel or marine-grade aluminum.

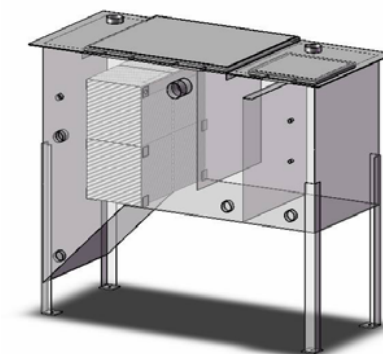

AIR STRIPPER MODULE:

MAE2's ADS-Series multi-stage, diffused-aeration stripper is used to remove dissolved volatile chemicals (VOCs) from the groundwater in each MPET-Series system. The diffused-aeration stripper acts as a reservoir for the oil/water separator groundwater discharge. The reservoir is divided up into multiple compartments, each containing air diffusers located near the bottom. Air is introduced into each compartment through the diffusers, causing the VOCs to bubble to the reservoir surface and transfer from liquid phase to vapor phase. The vapors are collected and discharged through a port to the atmosphere, or can be treated using vapor-phase carbon vessels or an oxidizer if desired. A centrifugal transfer pump is used to discharge the clean groundwater for disposal or further treatment. Similar to the oil/water separator, the ADS-Series strippers can be fabricated from carbon steel.

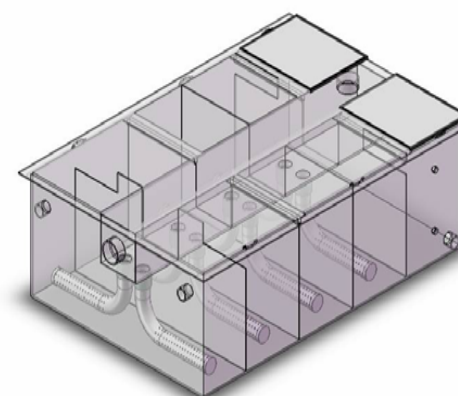

ENCLOSURE MODULE:

Each MPET-Series system is wired, tested and mounted in a modified shipping container. Our shipping containers offer a cost-effective, customizable solution for enclosing remediation systems. Some of the standard container features include insulated walls and ceiling, thermostat controlled heater and fan, painted exterior and interior, and barn-style swing doors. The layout of the system components in each MPET-Series system is arranged to accommodate easy access for maintenance and equipment servicing. MAE2 can also provide wind-load documentation, signed and stamped by a state approved Professional Engineer (PE) for these containers, if requested. The documentation would be in compliance with the local building code for the location of the site.

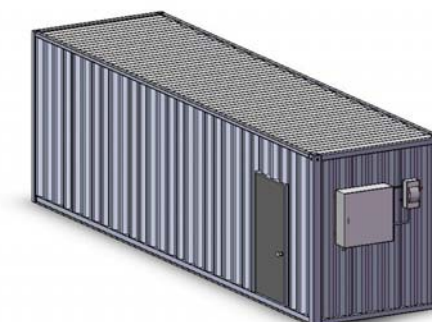

CONTROL SYSTEM MODULE:

The MAE2 Direct Logic PLC-Based Control Panel is the standard control system used in each MPET-Series system. These panels come UL-certified and are capable of controlling a system at any level of complexity. They can be expanded to accommodate transmitters for data-logging purposes. As a standard the PLC control system is mounted in a lockable NEMA 4 enclosure with an inner swing panel, which is mounted to the enclosure exterior. The appropriate hand/off/auto switches, motor-run lights, alarm-indicator lights, alarm-reset button and emergency stop button for each system are installed on the inner swing panel. The control system can also be upgraded to include wireless, web-based telemetry for remote system control and system alarm notification.

